

O-SPA - Pallet Feet

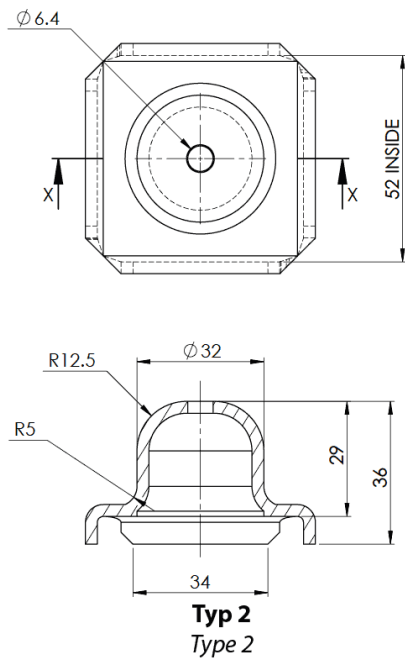
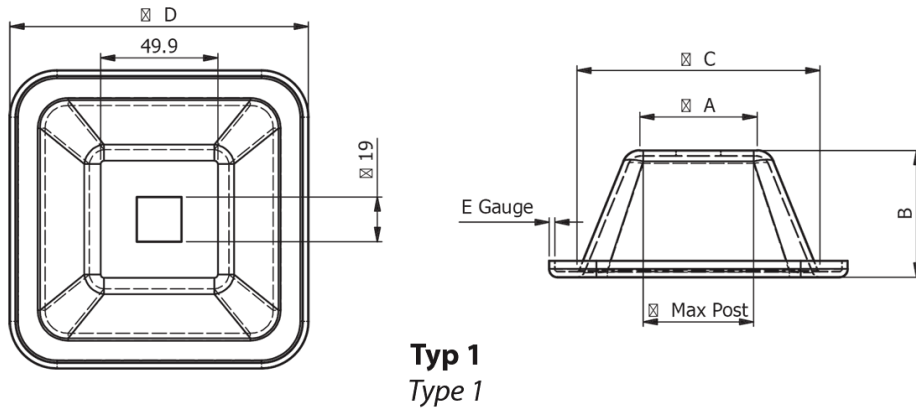

Details:

- Pressed Self-colour Mild Steel
- Suitable for welding onto SHS tube
- Maximum post sizes assume SHS to be used
- Maximum post sizes will be less when sharp-cornered squares are used
- Maximum strength is achieved with maximum post size
- Type 2 is stackable

Symbol	Type	A	B	Hole	C	D	E	Maximum post size	Material
		[mm]	[mm]	[mm]	[mm]	[mm]	[mm]	[mm]	
O-SPA-70165	1	70	70	19	127	165	3	80	steel